

2116-184 Block Downconverter

The 2116-184 Block Downconverter converts 17.3 - 18.4 GHz to 0.95 - 2.05 GHz with a local oscillator at 16.35 GHz. Front panel LEDs provide indication of DC power, external 10 MHz, and PLL alarm. The RF to L-band gain is +25 dB. Connectors are SMA female for the RF and BNC female for the L-Band and external reference input and reference output. A three-way switch controls which 10 MHz reference is being used. In the INT position, the internal reference is used, in the EXT position, the external reference is used, and in the AUTO position, the internal reference is used unless a +3 dBm ± 3 dB, 10MHz reference signal is connected to the external reference input. The 2116 is powered by a 100-240 ±10% VAC power supply, and mounted in a 1 3/4" X 19" X 14" rack mount chassis.

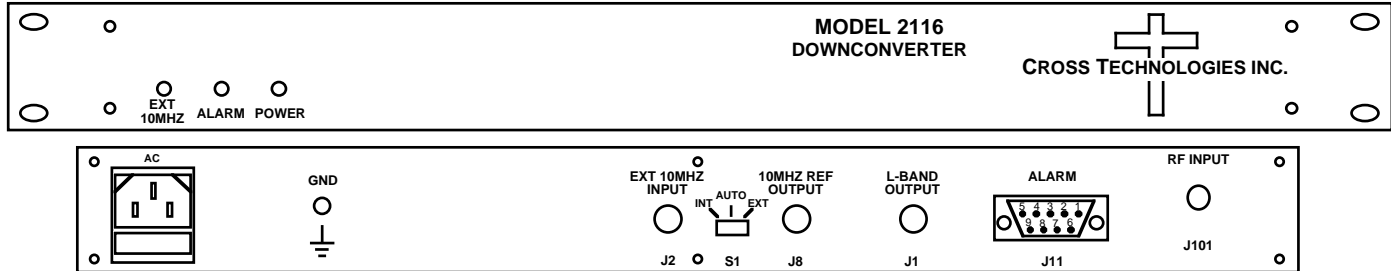

Front and Rear Panels

EQUIPMENT SPECIFICATIONS*

Input Characteristics

Impedance/Return Loss 50Ω/14 dB
 Frequency 17.3 - 18.4 GHz
 Noise Figure, Max. 20 dB max gain
 Input Level range -55 to -35 dBm
 Input 1 dB compression -25 dBm

Output Characteristics

Impedance/Return Loss 50 Ω /12 dB
 Frequency 0.95 - 2.05 GHz
 Output Level Range -30 to -10 dBm
 Output 1 dB compression 0 dBm

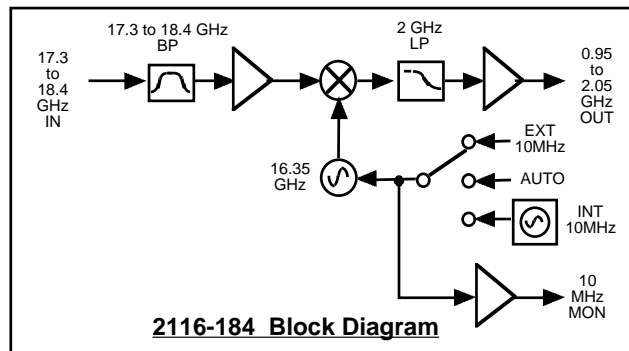

Channel Characteristics

Gain +25 dB ±2 dB
 Image Rejection > 50 dB, min
 Spurious, Inband SIGNAL RELATED <-50 dBC in band, -10 dBm out; SIGNAL INDEPENDENT, <-60 dBC
 Spurious, Out of band <-50 dBm
 Intermodulation <-50 dBC for two carriers each at -13 dBm out
 Frequency Response ±2.0 dB, 0.95 - 2.05 GHz out; ± 0.75 dB, 40 MHz BW
 Frequency Sense Non-inverting

LO Characteristics

LO Frequency 16.35 GHz
 Frequency Accuracy ± 0.01 ppm max over temp internal reference; ext. ref. input

Phase Noise @ F (Hz) >	100	1K	10K	100K	1M
dBC/Hz	-60	-70	-80	-100	-115

10 MHz level +3 dBm, ± 3 dB, 75 ohms, External In or Internal out

Controls, Indicators

Ext 10 MHz Yellow LED, indicates external 10 MHz reference selected (rear panel DPDT switch)
 PLL Alarm Red LED, External contact closure
 Power Green LED

Other

RF Connector SMA (female), 50Ω
 L-Band Connector BNC (female), 50Ω
 10 MHz connectors BNC (female), 75Ω connector; Works for 50Ω/75Ω
 Alarm Connector DB9 - NO or NC contact closure on Alarm
 Size 19 inch standard chassis 1.75" high X 14.0" deep
 Power 100-240 ±10% VAC, 47 - 63 Hz, 25 watts max.

Available Connector Options

S7 - 50Ω SMA (RF), 75Ω BNC (L-BAND)
 SF- 50Ω SMA (RF), 75Ω F-type (L-BAND)
 SN - 50Ω SMA (RF), 50Ω N-type (L-BAND)
 SS - 50Ω SMA (RF), 50Ω SMA (L-BAND)

*+10 to +40 degrees C; Specifications subject to change without notice